

ACCESS AL SERIES LOADERS



Access Model AL-2
with ELC-M control

EASIER ACCESS FOR SIMPLIFIED CLEANING

Cleaning and maintaining your loaders is now faster, easier and safer than ever before. That's because the unique angled canister design of the Conair Access Loader (AL) means workers don't need to climb as high or work as hard to service the drop-in filter or wipe out the stainless steel canister.

VALUE-ADDED FEATURES AT NO ADDITIONAL COST

The Access Loader (AL) series delivers all the performance and reliability you expect from Conair, plus added features and benefits at no extra cost. A hinged filter lid opens easily, without tools, tilts back and locks out of the way leaving both hands free for safety and comfort. Filter cleaning blowback is a standard feature.

The powerful vacuum motor is covered by a sound-dampening plastic housing that is both attractive and durable. For more robust loading applications, the AL can be ordered with a long-life, extra-powerful brushless motor.

Units are equipped with the *new* Easy Loading Controls (ELC) featuring bright, clear readouts displaying when the loader is conveying and when it is in demand for material. Additional control functions are available with the addition of the optional ControlMate pendant.

- **The world's most reliable discharge valve**
Now in cast aluminum, for years of trouble-free performance.
- **Select option packages to suit your needs**
Popular options are combined for easy selection and integrated into your loader purchase.
- **Full featured control** NEW
The new Easy Loading Control (ELC) and optional ControlMate pendant govern all aspects of your Access Loader including: load time, material demands, purge, ratio and many other loading parameters!
- **Optional customizable ratio valve**
The ratio valve's top and bottom material inlets can be conveniently positioned facing forward or backwards for convenient connection to your material lines.

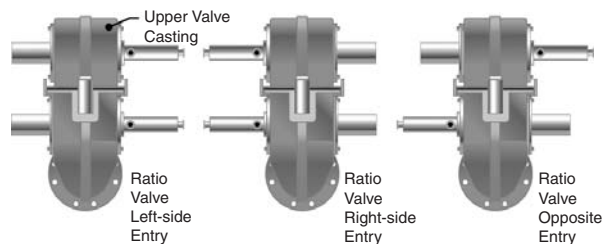

New Loading Control

The ELC-M displays the loader's sequence within its conveying cycle with icons and associated LEDs. The control has precise, reliable electronics for operation, programming and alarms.



How It Works

A signal from the loader's demand switch indicates to the ELC-M on the loader that it requires material to be conveyed to satisfy its demand. The ELC-M sends a signal to the vacuum motor on the loader to energize and start a loading cycle. The material is then drawn in by the loader's vacuum motor. If the hopper is filled, the demand switch will remain open (Fig. 1) and no further load cycles will be needed. However, if the demand was not satisfied and the demand switch closes (Fig. 2) the loader will continue with loading cycles until the demand is satisfied.

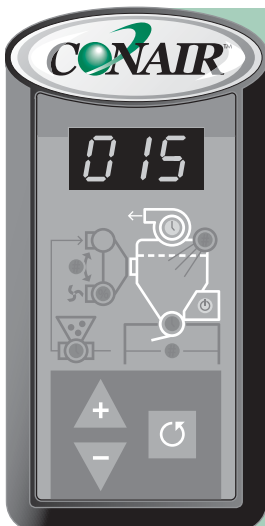

Fig. 1



Fig. 2

Optional ControlMate™ Pendant



ELC ControlMate™ Pendant

The ControlMate pendant consists of eight LEDs, a three-digit numeric display and three push buttons.

The ControlMate comes with an ethernet cable that supplies power and communications to the pendant from the main ELC control.

Control Features

- **Interchangeable programming** - One optional pendant can be used to control all ELC controls within your system. The ControlMate pendant can be used with either the ELC-M or ELC-16.
- **Change up to 16 parameters** - Eight standard control parameters are accessible through User Level 1. An additional eight parameters are accessed through User Level 2. These additional parameters activate loading options such as: priority demand, fill sensor logic, demand sensor logic, fill sensor present, load and hold, purge/ Adjustable Purge Valve (APV) installed, ratio installed, blow back installed.
- **Easy-to-read display** - Both the ControlMate pendant and the ELC control use icons and associated LEDs to symbolize various loading parameters.

Control Function

- 1 **Push the Function button**  **until the appropriate LED indicator is illuminated** to change any loading parameter.
- 2 **Use the (+) or (-) buttons located to the left of the Function button** to change a loading parameter to your requirements.
- 3 **Once your parameters are changed there is no need for further keys strokes,** all parameters are instantly saved to the ELC control.

ControlMate User Level 1 Parameters

- On/Off
- Unload Time
- Load Attempts
- Ratio Layers
- Ratio Percentage
- Purge Time
- Load Time
- Blowback

FEATURES

SELF-CONTAINED VACUUM LOADERS

ACCESS AL SERIES LOADERS



Stainless steel cylindrical, angled body provides easy access to internal drop-in disc filter.

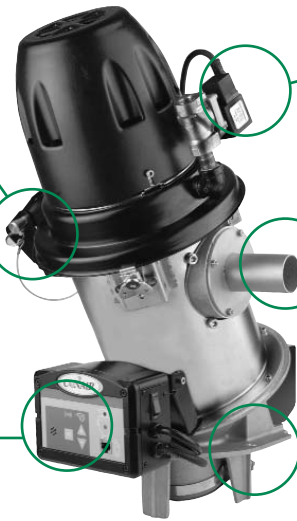

Blowback solenoid for the removal of dust or particulates that accumulate on the loader's internal disc filter.

Bolt-on replacement inlet/outlets (1.75 in. {44.45 mm} standard) vertical feed tube and flex hose clamps.

All material contact surfaces are built of pristine stainless steel or aluminum to prevent corrosion.

New ELC-M loading control with intuitive loader display. Enhanced control capabilities are possible with the optional ControlMate pendant.

Cast aluminum base
Protective stand-offs
Integral discharge pan

Options



Stainless Steel Hopper (JIT)

Mounts directly to a machine throat with a stainless steel hopper (JIT). Three sizes are available: 10 lb hopper for the AL-2 model loader and 20 and 40 lb hoppers for the AL-5 model. An air tight seal is not required at the base of the Access Loader due to the included isolator valve. A simple grate magnet may also be included in the cast base to catch tramp metal. A remote demand sensor bracket is included with 20 and 40 lb hoppers.



Glass Hopper

Mounts directly to a machine throat with a direct feed glass hopper. Three sizes are available for the AL-2 model loader only. An air tight seal is not required at the base of the Access Loader due to the included isolator valve. Quick-disconnect clamps allow easy loader removal for thorough cleaning. A simple grate magnet is available as an option and may be installed in the cast base to catch tramp metal. A remote demand sensor bracket is included.

Gravity Discharge Valve

The gravity discharge valve uses a non-contact, magnetic reed switch to signal loader demand. Stand-offs provide a rugged guard to prevent discharge valve damage. The large opening eliminates material bridging.

Remote Demand Sensor

To trigger the operation of the loader (demand) from a location other than directly below the loader, a remote demand sensor may be used. The remote demand sensor is useful on oversized drying hoppers to sense material through a sight glass. Extension cables are available.

Ratio Valve

A dual inlet, single outlet material valve that is mounted directly to the Access Loader allows the loading of a second material to be layered along with virgin material. Ratio Valve field retrofit kits are available.

Left-side Material Inlet

Rotates the position of the loader's material inlet 180°.

Volume Fill Sensor

Provides automatic shut-off of the loader's vacuum sequence when the loader is full. A LED will illuminate on the ELC control if the vacuum sequence has not satisfied the loader's demand.

High-wear Kit

T-1 tool steel deflector plate is added to the inside of the loader's body to reduce wear from highly abrasive materials, such as glass-filled compounds.



ACCESS AL SERIES LOADERS

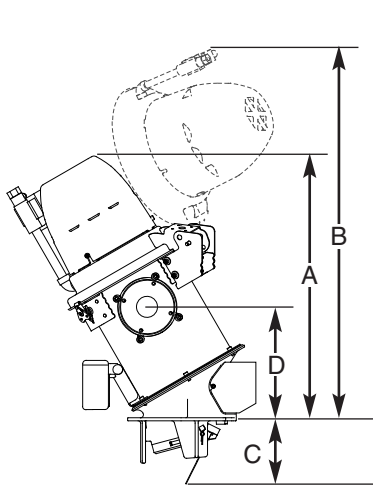

Standard Model

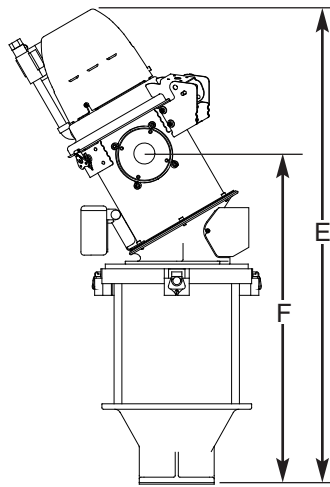

Direct Feed Model (Glass Hopper)

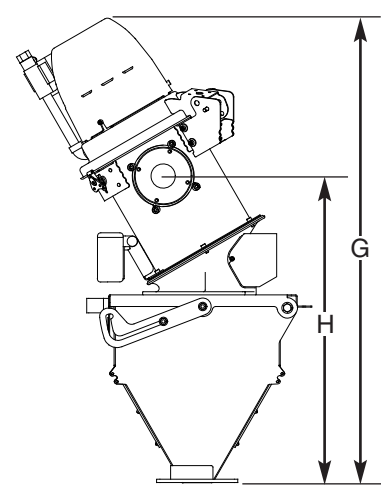

Direct Feed Model (Stainless Steel Hopper JIT)

MODEL	AL 2	AL 5	AL 5*
Performance characteristics			
Loader volume ft ³ (liters)	0.2 {6.0}		0.5 {14.0}
Loader Body Diameter inches (mm)	8.0 {203.0}		12.0 {304.0}
Material/vacuum line inches (mm)	1.5 - 2.0 {38 - 51}		1.5 - 2.0 {38 - 51}
Vacuum Motor	5/8 Hp - 2 Brush	7/8 Hp - 4 Brush	1.3 Hp - Brushless
Nominal throughput† lbs/hr {kg/hr}	200.0 {90.0}	500.0 {227.0}	1000.0 {454.0}
Maximum conveying distance ft (m)	50.0 {15.2}	75.0 {22.9}	120.0 {36.6}
Loader diameter inches (mm)	8.0 {203.0}		12.0 {304.0}
Discharge type	Gravity flapper or Positive discharge		
Demand sensor	Integrated reed switch / Remote capacitance sensor (optional)		
Dimensions inches (mm)			
A - Height above mounting plate	20.4 {518.2}		23.2 {588.52}
B - Height above mounting plate with open lid	29.7 {754.4}		34.0 {863.6}
C - Depth below mounting plate	4.9 {124.5}		8.1 {206.3}
with positive discharge	10 {254.0}		16.0 {406.0}
D - Height to center of material inlet	8.8 {223.5}		8.6 {219.5}
Mounting details			
	See FIG. 1		See FIG. 2
Approximate weight lb {kg}			
Installed	28 {13}		49 {22}
Shipping	50 {23}		65 {30}

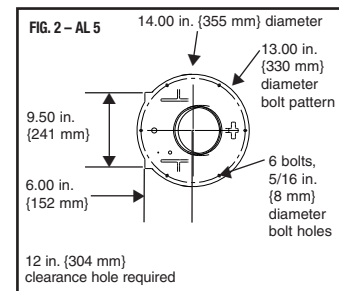
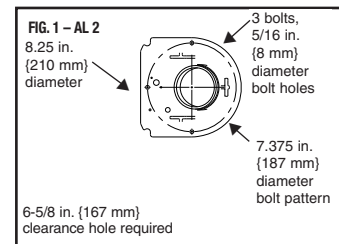

Direct Feed Model (Glass Hopper)

MODEL	AL 2		
Performance characteristics			
Viewing chamber model	3 lb	11 lb	21 lb
Viewing chamber capacity lb {kg}	3.0 {1.4}	11.0 {4.9}	21.0 {9.5}
Isolator valve	standard	standard	standard
Dimensions inches (mm)			
E - Height above mounting plate	32.4 {822.5}	38.1 {966.7}	49.6 {1260.6}
F - Height to center of material inlet	20.8 {527.1}	26.5 {672.6}	38.0 {965.2}
Mounting details			
	See FIG. 3		
Approximate weight lb {kg}			
Installed	43 {19}	49 {22}	59 {27}
Shipping	65 {30}	71 {32}	82 {37}

Direct Feed Model (Stainless Steel Hopper) JIT

MODEL	AL 2	AL 5	
Performance characteristics			
Viewing bin model	10 lb	20 lb	40 lb
Viewing bin capacity lb {kg}	11.1 {5.1}	24.3 {11.0}	41.5 {18.8}
Isolator valve	standard	standard	standard
Dimensions inches (mm)			
G - Height above mounting plate	34.3 {871.2}	42.1 {1069.3}	45.2 {1148.1}
H - Height to center of material inlet	22.6 {574.0}	27.7 {703.6}	30.8 {782.3}
Mounting details			
	See FIG. 3		
Approximate weight lb {kg}			
Installed	45 {20}	80 {36}	85 {39}
Shipping	67 {30}	96 {44}	101 {46}

SPECIFICATION NOTES:

- * Available with brushless motor as standard.
 - † Throughputs beyond the recommended ratings should not be attempted unless you are conveying virgin material from close distances. Higher throughputs could result in shortened brush and/or filter life. For higher throughputs, consult Conair for a quote on central vacuum loaders.
- All Access Loaders are shipped with 10 ft (3.048 m) of flex hose and a vertical feed tube.
 Specifications can change without notice. Contact your Conair representative for the most current information.

